

Molded Polymer Filter Silencers

PS Series 1/8" - 1"

Benefits

- Longer element life with maximized surface area
- Cost-efficient solution
- Low restriction improves equipment performance

Features

- Easy snap-on design for quick servicing
- Durable glass reinforced nylon housing
- Compact, low profile configuration
- Noise reducing silencing design
- High grade filter element with integrated gasket seal



Technical Specifications

- Temp (continuous): min -15°F (-26°C) max 220°F (104°C)
- Filter change out differential: 15-20" H₂O over initial ΔP
- Pressure drop graphs available upon request
- Polyester: 99%+ removal efficiency standard to 10 micron
- Paper: 99%+ removal efficiency standard to 2 micron

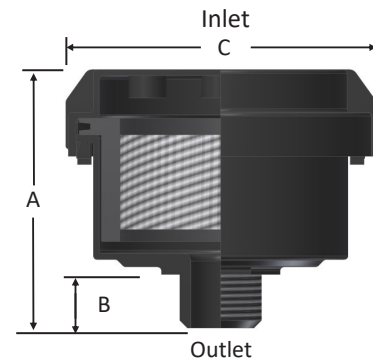

MPT Outlet	Assembly SCFM Rating	Assembly Part Number		Dimensions - inches			Suggested Service Ht. inches	Approx. Weight lbs	Replacement Element Part No.		Element SCFM Rating
		Polyester	Paper	A	B	C			Polyester	Paper	
1/8"	3	PS-03-013	PS-02-013	1 3/4	7/16	1 3/4	1	0.05	03™	02™	3
1/4"	3	PS-03-025	PS-02-025	1 3/4	7/16	1 3/4	1	0.05	03™	02™	3
1/4"	4	PS-05-025	PS-04-025	2 1/8	1/2	2 5/8	1	0.09	05™	04™	8
3/8"	6	PS-05-038	PS-04-038	2 3/16	1/2	2 5/8	1	0.09	05™	04™	8
1/2"	6	PS-05-050	PS-04-050	2 3/16	1/2	2 5/8	1	0.09	05™	04™	8
1/2"	10	PS-07-050	PS-06-050	3 1/8	11/16	3 1/4	2	0.20	07™	06™	12
1/2"	12	PS-11-050	PS-10-050	3 1/4	11/16	4 1/8	2	0.30	11™	10™	35
3/4"	12	PS-07-075	PS-06-075	3 1/4	1	3 1/4	2	0.30	07™	06™	12
3/4"	20	PS-11-075	PS-10-075	3 1/2	1	4 1/8	2	0.35	11™	10™	35
1"	35	PS-11-100	PS-10-100	3 3/4	1 1/4	4 3/16	2	0.40	11™	10™	35

See Filter Silencer Technical Data for sizing guidelines.