

EC3-122403DSL - 12KW 240/415V

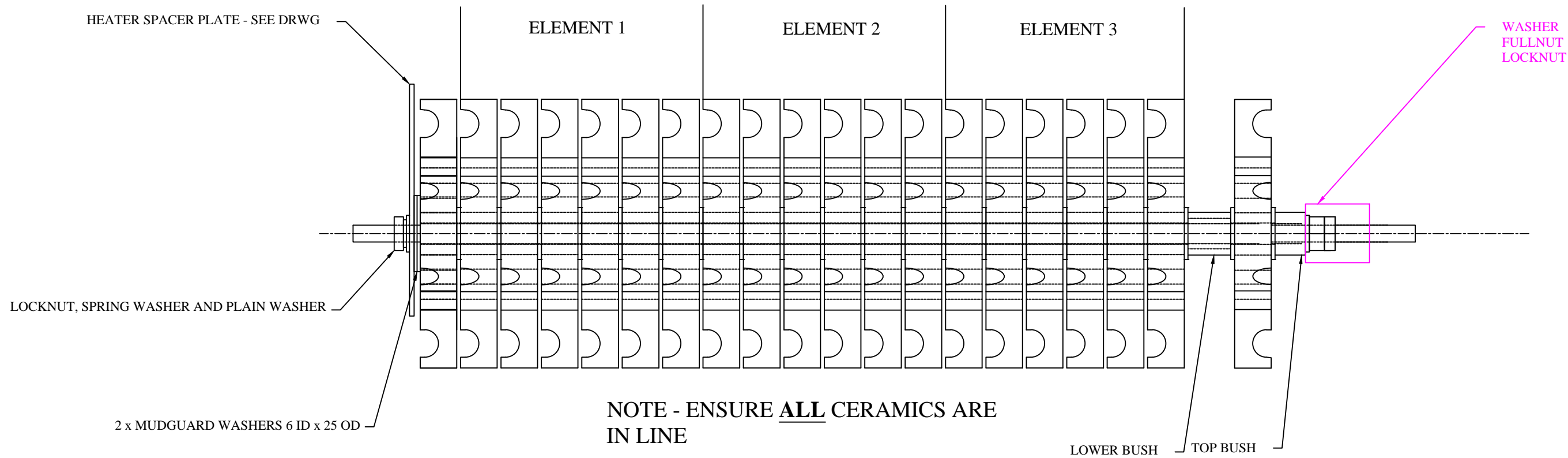

MARK LEADS WITH SHRINK TUBE
L1 = BROWN
L2 = BLACK
L3 = GREY
N1, N2 & N3 = BLUE
DO NOT SHRINK
FASTEN IN PLACE WITH CABLE TIE

MARK ENDS OF TOP CERAMIC N1, L1 etc. AS DRAWING

TERMINAL POST DETAIL

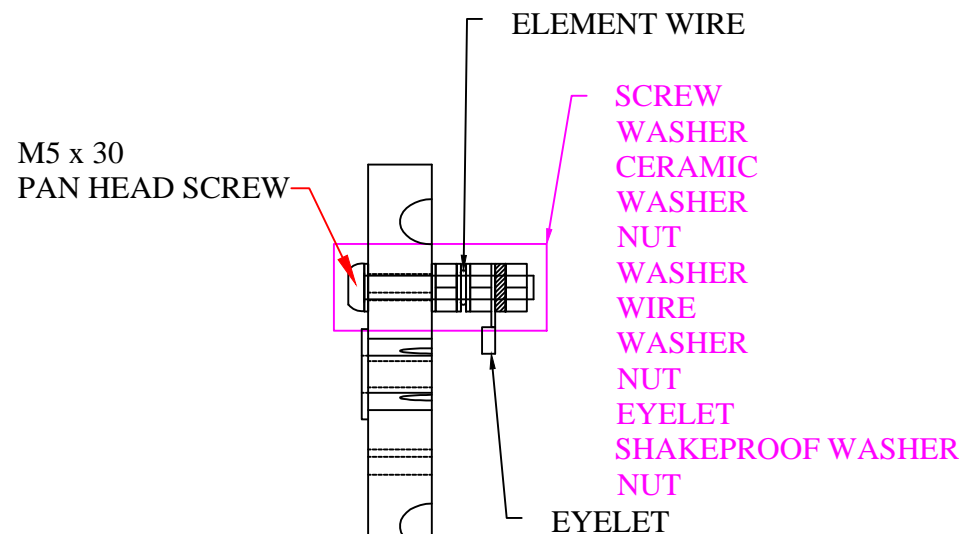

ELEMENT WIRING LAYOUT

12KW 240/415V 3 PHASE STAR UNIT - 14.4 Ohms PER ELEMENT / ZONE
20 SWG SPIRAL ON A Ø4mm MANDREL
APPROX. 21" WIND - 52" STRETCH - LEAVE 12" STRAIGHT ON ENDS

FIT GLASS FIBRE LEADS 16" LONG - 6 x 20 AMP
FIT ALL LEADS WITH YELLOW INSULATED EYELETS
MARK LEADS WITH SHRINK TUBE AS DRAWING - DO NOT SHRINK ON - FASTEN WITH CABLE TIE

FEED STRAIGHT LEGS THROUGH HOLES IN FORMERS AND WRAP AROUND TERMINAL SCREWS.
MARK SIDES OF TOP CERAMIC WITH:

HEA1017
12KW
240/415V
EC3-122403DSL
Job no.
Customers order no.

REV	REVISION	DATE
1	WIRE CHANGE FROM 19SWG ON Ø4.5 TO 20SWG ON Ø4	

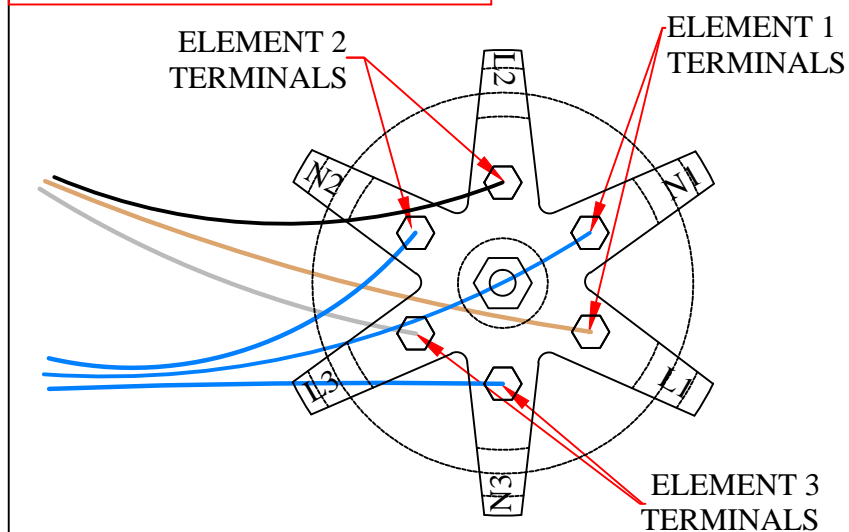

SPECIFICATION

AIR HEATER 12KW 240/415V - FOR USE IN CONTINUOUS AIR FLOW

METRIC TOLERANCES UNLESS SPECIFIED
2 PLACES OF DECIMALS ± 0.05
1 PLACE OF DECIMALS ± 0.10
1-299 ± 0.25
300 & OVER ± 0.50
THREADS TO BE BS 3643 (MEDIUM FIT)

Drawn	S.T.
Checked	
Date	18/10/2017

TITLE AIRTEC AIR HEATER EC3-122403DSL

DRAWING No.	REV
EC3-122403DSL	